

BK-G40 / 65 / 100

Industrial diaphragm gas meters



Applications

Media: Natural gas, city gas, propane, butane, inert gases
Branches: Gas industry
Tasks: Measuring of the actual volume

Brief information

The metering gear of the BK-G40, BK-G65 and BK-G100 industrial diaphragm meters consists of up to 8 measuring units (depending on the size of the meter) operating in parallel. Each of the measuring units contains 4 measuring chambers, separated from each other by synthetic diaphragms. The chambers are periodically filled and emptied. A gear transmits the movement of the diaphragm to the corresponding crankshaft. The shaft then drives the valves which control the gas flow. The revolutions of the gear are transmitted via a magnetic coupling to the index.

Elster-Instromet's industrial diaphragm meters are compact, easy to handle and have a perfect weight ratio. They meet the highest standards in terms of metering accuracy and safety. The BK series of industrial diaphragm meters combines innovative new developments with decades of Elster-Instromet experience. The meters come with a deep-drawn, screwed, or welded, steel housing and can be supplied either with coaxial or twin-pipe connections.

The measuring units in the industrial diaphragm meters operate in line with the principle of pneumatic control, meaning less force is exerted on the bearings, which results in low-noise operation.

The well-proven and patented K-System for adjusting and synchronising the measuring units together with the use of high-grade materials guarantees a high degree of quality and metering accuracy.

The use of small valves ensures that the industrial diaphragm meters are Q_{\min} stable and are not susceptible to dirt or any other contamination.

The new generation of industrial diaphragm meters are extremely robust but should, nevertheless, be handled with the same care that every metering device deserves.

Main features

- MID conformity approved by PTB
- EC-approved by German PTB for flow rates from 0.40 m³/h to 160 m³/h
- Approved to EN 1359 by German DVGW
- Cyclic volume:
BK-G40: 18 litres
BK-G65: 24 litres
BK-G100: 48 litres
- Maximum operating pressure 0.5 bar (0.1 bar for fireproof applications to EN 1359)
- High accuracy and long term reliability
- Powder coated pale grey to RAL 7035
- Pulse magnet as standard; a LF-pulser can be added at any time ($I = 0.1 \text{ m}^3/\text{pulse}$)
- Low noise level
- Not susceptible to contamination (RPF=0.8)
- Gas temperature: -10 °C to +40 °C other temperatures on request
- Compact and handy design
- Option: Reverse flow valve

BK-G40, BK-G65 and BK-G100: Industrial diaphragm gas meters

BK-G40 and BK-G65: Dimensions and weights

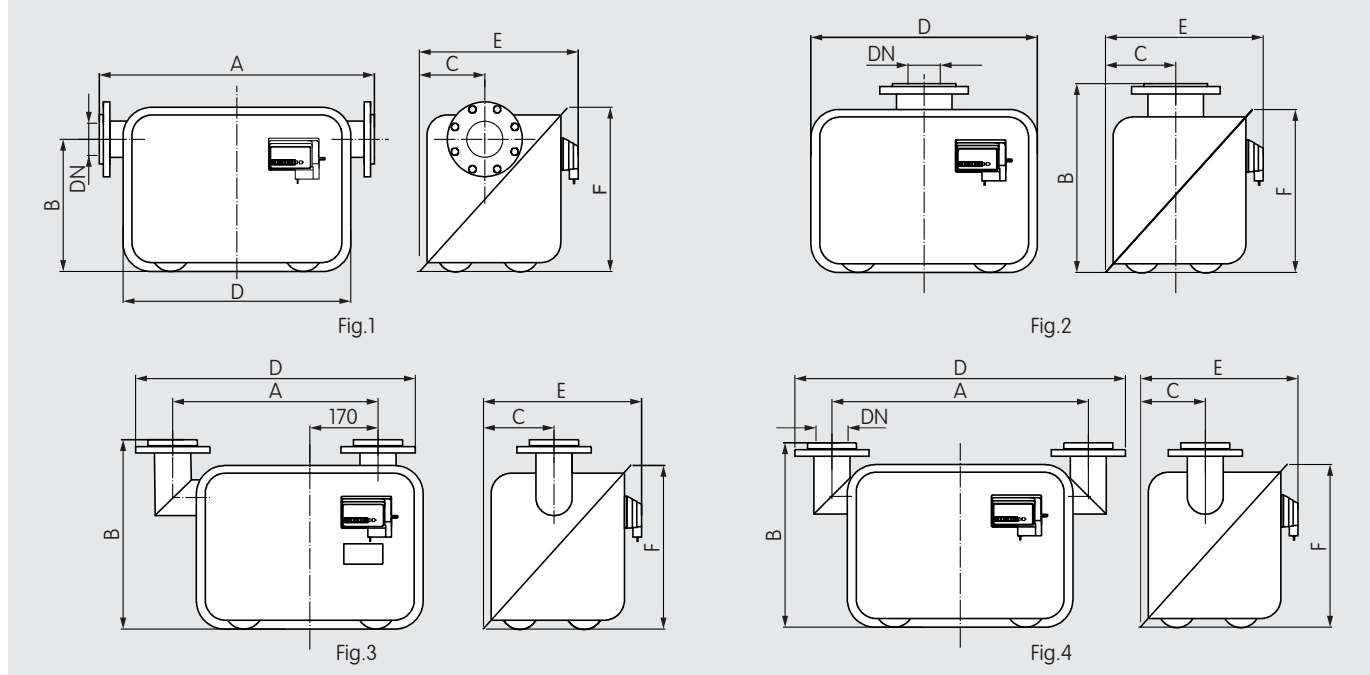

Fig.	Type	Q _{max} [m ³ /h]	Q _{min} [m ³ /h]	V [dm ³]	Mounting flange***		Dimensions						Weight [kg]
					Standard	Optional	A****	B	C	D	E	F	
1	BK-G40	65	0.40	18	DN80	DN65	570	327	161	564	392	403	28
2	BK-G40	65	0.40	18	DN80**	DN65**	-	470	175	564	392	403	26
3	BK-G40	65	0.40	18	DN80	DN65	510	470	175	710*	392	403	29
1	BK-G65	100	0.65	24	DN80	DN100	680	327	161	564	392	403	29
2	BK-G65	100	0.65	24	DN80**	-	-	470	175	564	392	403	28
4	BK-G65	100	0.65	24	DN80	DN100	640	460	161	840*	392	403	32

* for DN80

** according to DIN 3376

*** flanges according to DIN 2642, PN10

**** other dimensions on request

BK-G40 and BK-G65: Pressure loss and error curve

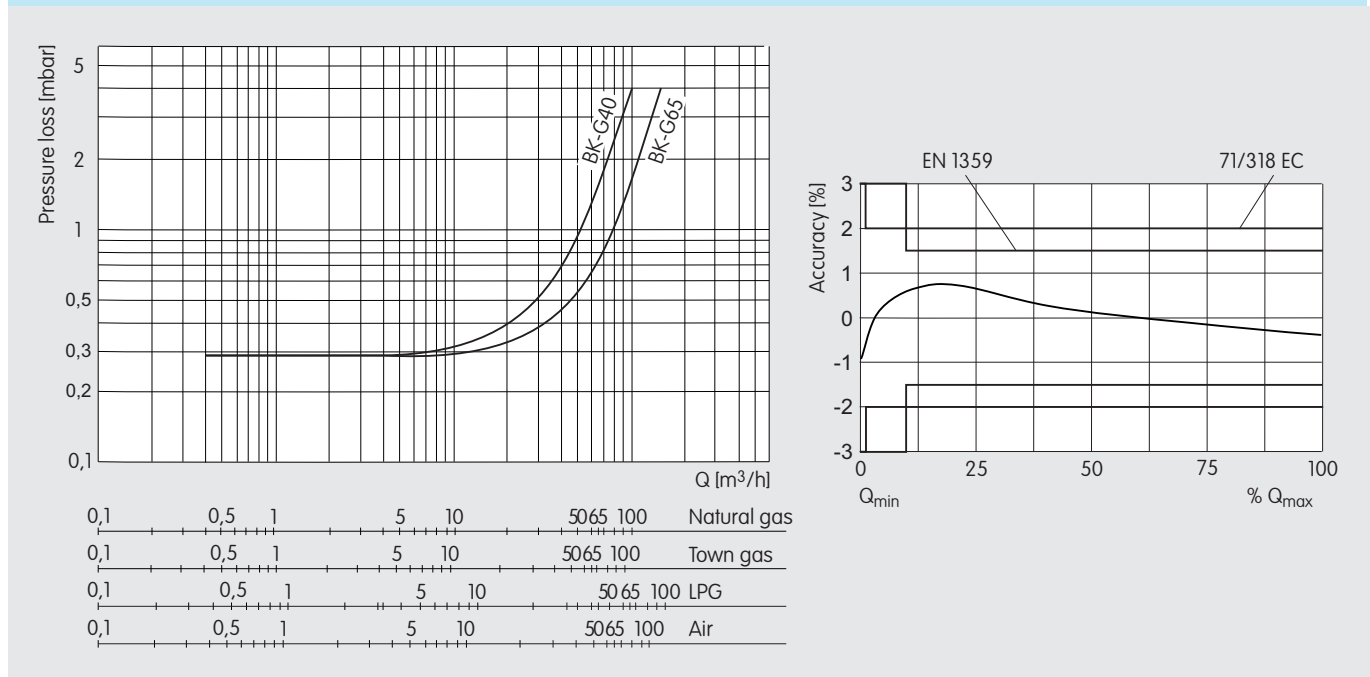

BK-G100: Dimensions and weights

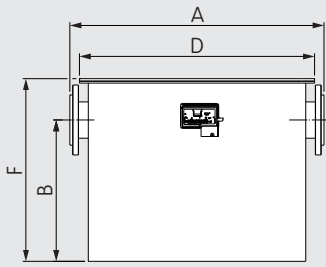

Fig.1

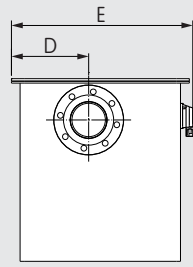

Fig.2

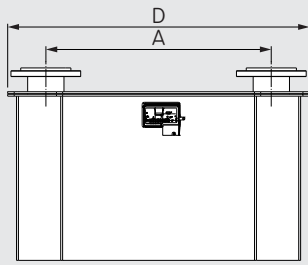
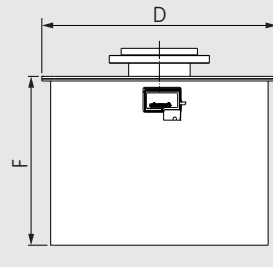

Fig.3

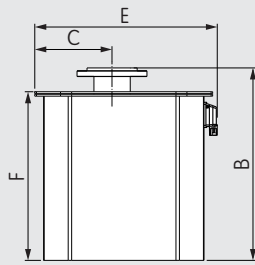

Fig.4

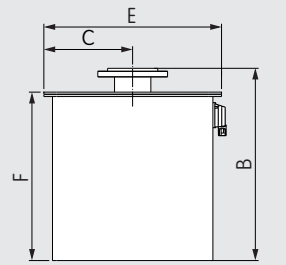
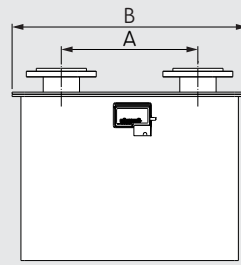
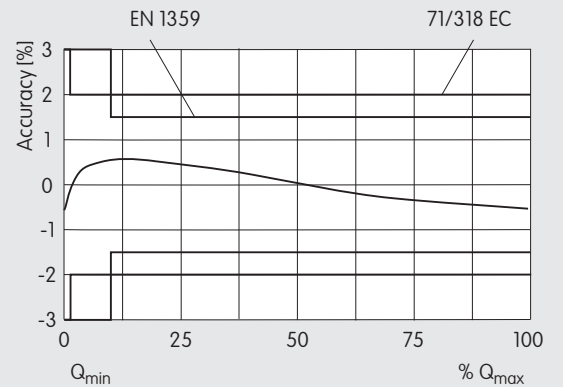
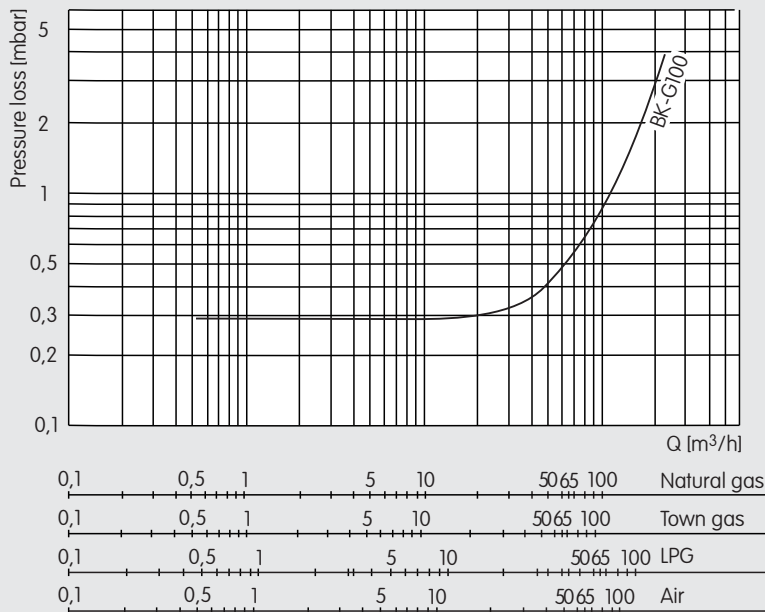

Fig.	Type	Q _{max} [m ³ /h]	Q _{min} [m ³ /h]	Mounting flange	Dimensions (mm)						Weight (kg)
					A	B	C	D	E	F	
1	BK-G100	160	1	DN100	800	448	243	740	571	577	95
2	BK-G100	160	1	DN100	-	621	243	740	571	533	100
3	BK-G100	160	1	DN100	710	608	243	950	571	533	105
4	BK-G100	160	1	DN100	430	608	280	740	571	533	95

BK-G100: Pressure loss and error curve



BK-G40, BK-G65 and BK-G100: Industrial diaphragm gas meters

Versions



BK-G40 / BK-G65



BK-G100

Industrial gas meter with Absolut-ENCODER technology (option)



- Transferred data:
- Meter reading
 - Meter type
 - Serial number
 - Media
 - Manufacturing date



Schematic representation of transferring the original meter reading via SCR interface to a data logger DL210
The Absolut ENCODER index is available with the M-BUS and SCR interface variants.

Your contacts

Germany
Elster GmbH
Steinern Str. 19 - 21
55252 Mainz-Kastel
T +49 6134 605 0
F +49 6134 605 223
www.elster-instromet.com
info@elster-instromet.com

Belgium
Elster-Instromet N.V.
Rijkmakerlaan 9
2910 Essen
T +32 3 670 0700
F +32 3 667 6940
www.elster-instromet.com
info@elster-instromet.com

Singapore
Elster-Instromet Sdn. Bhd. (Singapore Branch)
160 Paya Lebar Road
#04-01 Orion@Paya Lebar
Singapore 409022
T +65 6247 7728
F +65 6247 7729
sales@elster-instromet.com.sg

BK 40 100 EN03

A12.08.2008